



Steel Wire Nails

• 1 lb box



Size	Item	Price per box	
		1-10	11+
1/2" x 18	TNN0418	\$4.00	\$3.40
5/8" x 17	TNN0517	3.52	2.99
5/8" x 18	TNN0518	3.72	3.16
3/4" x 16	TNN0616	3.30	2.81
3/4" x 17	TNN0617	3.32	2.82
3/4" x 18	TNN0618	3.44	2.92
3/4" x 19	TNN0619	3.88	3.30
3/4" x 20	TNN0620	4.50	3.83
7/8" x 18	TNN0718	3.44	2.92
1" x 16	TNN0816	3.16	2.69
1" x 17	TNN0817	3.16	2.69
1" x 18	TNN0818	3.24	2.75
1 1/4" x 15	TNN1015	2.92	2.48
1 1/4" x 16	TNN1016	2.92	2.48
1 1/4" x 17	TNN1017	3.16	2.69
1 1/4" x 18	TNN1018	3.24	2.75

Steel Wire Brads

• 1 lb box



Size	Item	Price per box	
		1-10	11+
1/2" x 18	TNB0418	\$4.00	\$3.40
5/8" x 18	TNB0518	4.26	3.62
5/8" x 20	TNB0520	4.88	4.15
3/4" x 16	TNB0616	3.30	2.81
3/4" x 17	TNB0617	3.32	2.82
3/4" x 18	TNB0618	3.44	2.92
3/4" x 19	TNB0619	3.88	3.30
3/4" x 20	TNB0620	4.50	3.83
7/8" x 16	TNB0716	3.28	2.79
7/8" x 18	TNB0718	4.48	3.81
1" x 16	TNB0816	3.16	2.69
1" x 17	TNB0817	3.16	2.69
1" x 18	TNB0818	3.24	2.75
1" x 19	TNB0819	3.80	3.23
1" x 20	TNB0820	4.50	3.83
1 1/4" x 14	TNB1014	2.92	2.48
1 1/4" x 15	TNB1015	2.92	2.48
1 1/4" x 16	TNB1016	2.92	2.48
1 1/4" x 17	TNB1017	3.16	2.69
1 1/4" x 18	TNB1018	3.24	2.75

Corrugated Fasteners

• 1 lb box

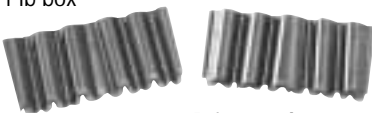

Size	Item	Price per box		
		1-10	11-19	20+
3/8"	FE3153	\$3.28	\$2.95	\$2.71
1/2"	FE3154	4.08	3.67	3.37
5/8"	FE3155	4.92	4.43	4.06

Drywall Screws

• Phillips head



Size	Item	Price per 1000	
		1000-4000	5000+
1"	DWDW08	\$7.04	\$6.03
1 1/4"	DWDW10	9.38	8.04
1 5/8"	DWDW13	10.55	9.05
2"	DWDW16	12.90	11.06
2 1/4"	DWDW18	15.24	13.07
2 1/2"	DWDW20	24.15	20.70
3"	DWDW24	28.91	24.78
4"	DWDW32	51.88	44.46

Brass Flathead Wood Screws

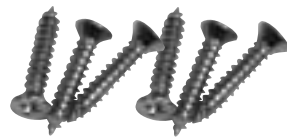

Size	Item	Price per 100	Price per 1000	
		100-900	1000-4900	5000+
4 x 5/8"	FB00458	\$1.49	\$6.00	\$5.15
4 x 3/4"	FB00434	1.49	6.62	5.67
5 x 5/8"	FB00558	1.49	6.98	5.99
5 x 3/4"	FB00534	1.49	7.63	6.54
5 x 1"	FB0051	1.49	10.13	8.69
6 x 5/8"	FB00658	1.49	7.47	6.41
6 x 3/4"	FB00634	1.49	8.37	7.17
6 x 1"	FB0061	1.49	10.33	8.85
6 x 1 1/4"	FB006114	1.49	12.51	10.73

Twin Fast Phillips Flathead Wood Screws

• The fastest & easiest screw to use in hard wood.



Size	Item	Price per 1000	
		1000-4900	5000+
8 x 1"	DWTF08	\$14.82	Call
8 x 1 1/4"	DWTF10	14.82	Call
8 x 1 1/2"	DWTF12	17.22	Call
8 x 1 3/4"	DWTF14	19.40	Call
8 x 2"	DWTF16	22.68	Call
8 x 2 1/4"	DWTF18	26.31	Call
8 x 2 1/2"	DWTF20	30.44	Call
8 x 2 3/4"	DWTF22	31.82	Call
8 x 3"	DWTF24	34.77	Call
TRIM HEAD			
8 x 1 5/8"	DWSH13	21.00	Call
8 x 2 1/4"	DWSH18	24.00	Call

Flat Head Phillips Bugle Head (Grabber)

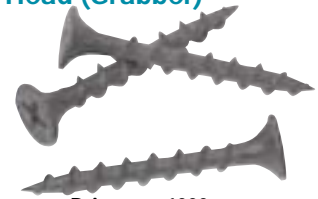

Size	Item	Price per 1000	
		1000-4900	Full Case
6 x 1"	DWDT08	\$8.30	Call
6 x 1 1/8"	DWDT09	9.60	Call
6 x 1 1/4"	DWDT10	9.10	Call
6 x 1 5/8"	DWDT13	11.80	Call
7 x 2"	DWDT16	17.50	Call
7 x 2 1/4"	DWDT18	19.10	Call
7 x 2 1/2"	DWDT20	25.40	Call
8 x 3"	DWDT24	29.50	Call

Deep Thread Phillips Flathead Screws

- Unusually deep, wide spaced threads are ideal for wood and wood composites.
- Provides easy driveability at higher speeds along with increased pitch.
- Deep thread combined with no-shank taper provides excellent holding power.

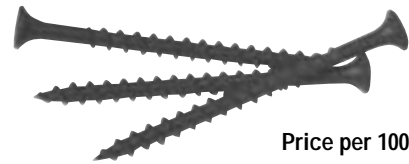

Size	Finish	Item	Price per 1000
			1000-4000
6 x 1/2"	Zinc	DWDT0612ZP	\$5.32
6 x 5/8"	Nickel	DWDT0658NP	7.35
6 x 3/4"	Nickel	DWDT0634NP	6.23
8 x 1"	Black	DWDT3D08	9.49
8 x 1 1/4"	Black	DWDT3D10	10.50
8 x 1 1/2"	Black	DWDT3D12	12.64
8 x 1 5/8"	Black	DWDT3D13	13.76
8 x 1 3/4"	Black	DWDT3D14	15.50
8 x 2"	Black	DWDT3D16	16.40
8 x 2 1/4"	Black	DWDT3D18	19.65
8 x 2 1/2"	Black	DWDT3D20	24.17
8 x 3"	Black	DWDT3D24	28.91

Hanger Bolts

• Sold per box of 100

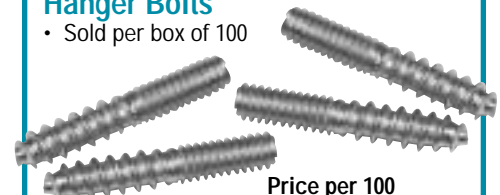

Size	Item	Price per 100	
		100-300	Full Case
8/32 x 1"	HANG8321	12.87	Call
8/32 x 3/4"	HANG83234	11.48	Call

- Check out Storage & Convenience
- Check out Keyboard Slides

Sheet Metal Screws

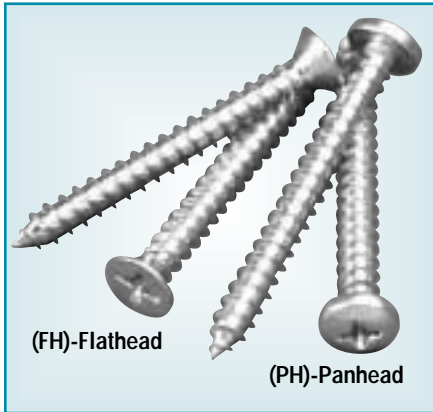

(FH)-Flathead

(PH)-Panhead

Pan Head Screws

Size	Item	Price per box of 100		
		1-9 box	10-49 box	Case
4 x 1/2	PH00412	\$4.99	\$5.99	Call
4 x 5/8	PH00458	4.99	5.99	Call
4 x 1	PH0041	4.99	6.99	Call
6 x 3/8	PH00638	4.99	5.99	Call
6 x 1/2	PH00612	4.99	5.99	Call
6 x 5/8	PH00658	4.99	5.99	Call
6 x 3/4	PH00634	4.99	7.99	Call
6 x 7/8	PH00678	4.99	7.99	Call
6 x 1	PH0061	4.99	8.99	Call
6 x 1 1/4	PH006114	4.99	10.99	Call
6 x 1 1/2	PH006112	4.99	11.99	Call
8 x 1/2	PH00812	4.99	7.99	Call
8 x 5/8	PH00858	4.99	8.99	Call
8 x 3/4	PH00834	4.99	9.99	Call
8 x 7/8	PH00878	4.99	10.99	Call
8 x 1	PH0081	4.99	10.99	Call
8 x 1 1/4	PH008114	4.99	12.99	Call
8 x 1 1/2	PH008112	4.99	15.99	Call
8 x 1 3/4	PH008134	4.99	17.99	Call
8 x 2	PH0082	4.99	20.99	Call
10 x 5/8	PH01058	4.99	11.99	Call
10 x 3/4	PH01034	4.99	12.99	Call
10 x 1	PH0101	4.99	14.99	Call
10 x 1 1/4	PH010114	4.99	17.99	Call
10 x 1 1/2	PH010112	4.99	19.99	Call
12 x 3/4	PH01234	4.99	17.99	Call
12 x 1 1/4	PH012114	4.99	23.99	Call
12 x 1 1/2	PH012112	4.99	27.99	Call
12 x 1 3/4	PH012134	6.99	31.99	Call
12 x 2	PH0122	6.99	34.99	Call
12 x 2 1/2	PH012212	9.99	42.99	Call
12 x 3	PH0123	11.99	49.99	Call
14 x 1 1/4	PH014114	4.99	27.99	Call
14 x 1 1/2	PH014112	4.99	31.99	Call
14 x 2	PH0142	6.99	38.99	Call
14 x 2 1/2	PH014212	11.99	45.99	Call

Flat Head Screws

Size	Item	Price	Price per 1000	
		per 100	1000-4900	5000+
4 x 3/8	FH00438	\$4.75	\$6.70	Call
4 x 1/2	FH00412	4.75	6.70	Call
4 x 5/8	FH00458	4.75	6.70	Call
4 x 3/4	FH00434	4.75	6.70	Call
4 x 1	FH0041	4.75	6.70	Call
5 x 1/2	FH00512	4.49	6.49	Call
5 x 5/8	FH00558	4.49	6.49	Call
5 x 3/4	FH00534	4.49	7.49	Call
5 x 1	FH0051	4.49	8.49	Call
6 x 3/8	FH00638	3.99	5.99	Call
6 x 1/2	FH00612	3.99	5.99	Call
6 x 5/8	FH00658	3.99	5.99	Call
6 x 3/4	FH00634	3.99	6.99	Call
6 x 7/8	FH00678	3.99	7.99	Call
6 x 1	FH0061	3.99	8.99	Call
6 x 1 1/4	FH006114	3.99	9.99	Call
6 x 1 1/2	FH006112	3.99	11.99	Call
6 x 1 3/4	FH006134	3.99	13.99	Call
6 x 2	FH0062	3.99	13.99	Call
8 x 1/2	FH00812	4.44	8.44	Call
8 x 5/8	FH00858	4.44	8.44	Call
8 x 3/4	FH00834	4.44	9.44	Call
8 x 7/8	FH00878	4.44	8.44	Call
8 x 1	FH0081	4.44	11.44	Call
8 x 1 1/4	FH008114	4.44	13.44	Call
8 x 1 1/2	FH008112	4.44	15.44	Call
8 x 1 3/4	FH008134	4.44	17.44	Call
8 x 2	FH0082	4.44	20.44	Call
8 x 2 1/2	FH008212	6.40	25.44	Call
8 x 3	FH0083	8.44	29.44	Call
10 x 1/2	FH01012	3.99	9.99	Call
10 x 5/8	FH01058	3.99	10.99	Call
10 x 3/4	FH01034	3.99	11.99	Call
10 x 1	FH0101	3.99	12.99	Call
10 x 1 1/4	FH010114	3.99	16.99	Call
10 x 1 1/2	FH010112	3.99	18.99	Call
10 x 1 3/4	FH010134	3.99	22.99	Call
10 x 2	FH0102	3.99	24.99	Call
10 x 2 1/4	FH010214	3.99	27.99	Call
10 x 2 1/2	FH010212	7.99	30.99	Call
10 x 2 3/4	FH010234	7.99	32.99	Call
10 x 3	FH0103	7.99	39.99	Call
12 x 1/2	FH01212	4.79	15.99	Call
12 x 3/4	FH01234	4.79	16.99	Call
12 x 1	FH0121	4.79	18.99	Call
12 x 1 1/4	FH012114	4.79	22.99	Call
12 x 1 1/2	FH012112	4.79	25.99	Call
12 x 1 3/4	FH012134	5.99	29.99	Call
12 x 2	FH0122	5.99	32.99	Call
12 x 2 1/2	FH012212	8.99	40.99	Call
12 x 3	FH0123	10.99	49.99	Call
14 x 3/4	FH01434	4.89	17.99	Call
14 x 1 1/4	FH014114	4.89	26.99	Call
14 x 1 1/2	FH014112	4.89	29.99	Call
14 x 2	FH0142	5.99	36.99	Call
14 x 2 1/2	FH014212	7.99	45.99	Call
14 x 3	FH0143	7.99	52.99	Call

The Ultimate

- Flat Head Phillips
- Heavy Gauge Body
- Two Thirds Threading
- Self Countersinking Nibs.
- Deep Threads: for better grip, especially useful in wood composites.
- Cuts into surface without predrilling. Fluting removes wood chips.

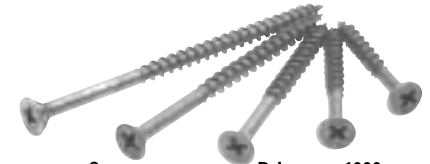

Sz./L	Case		Price per 1000	
	Qty.	Item	Price/1000	Case
8 x 1"	11,000	DWUL81Z	\$12.50	\$10.80
8 x 1 1/4"	9,000	DWUL8114Z	12.98	14.62
8 x 1 1/2"	7,000	DWUL8112Z	15.38	17.08
8 x 1 3/4"	4,800	DWUL8134Z	18.52	20.52
8 x 2"	3,000	DWUL82Z	21.22	23.22
8 x 2 1/4"	3,500	DWUL8214Z	25.12	27.42
8 x 2 1/2"	2,500	DWUL8212Z	30.34	32.64
8 x 3"	2,000	DWUL83Z	36.22	38.72

Euro Screws

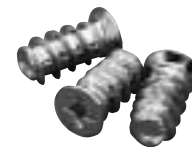

5mm Screw Dia.

Length	Item	Full Case	
		1-4 boxes	5+ boxes
10mm	DWES10MM	17.42	Call
11.5mm	DWES115MM	18.90	Call
13mm	DWES13MM	19.32	Call
20mm	DWES20MM	22.82	Call
25mm	DWES25MM	26.38	Call
30mm	DWES30MM	30.42	Call

Prices per box of 1000

Drawer Front Adjusters



Sz./L	Item	Price per 1000	
		100-900	1000
8 x 1/8"	DWMT878	\$27.52	\$22.52
8 x 1"	DWMT81	29.12	23.22
8 x 1 1/8"	DWMT8118	29.80	23.90
8 x 1 1/4"	DWMT8114	30.68	24.78



Self Adhesive Screw Cap Covers

Available in solid PVC colors, PVC wood tones and real wood which can be sanded, stained and finished. $\frac{5}{16}$ " diameter.

- Easy to use...Saves time!
- Attractive coverage for screw & nail holes.
- Lower profile, less noticeable than other caps.
- Packed 5 sheets of 52 caps per sheet for a total of 260 caps per box. Larger bulk packs are available, please inquire.

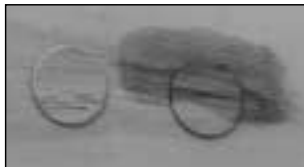

PVC Solids-Colors

Color	Item
White	FC.MB.916.WH
Antique White	FC.MB.916.AW
Almond	FC.MB.916.AL
Black	FC.MB.916.BL
Fog Gray	FC.MB.916.DG
Folkstone Gray	FC.MB.916.LG
Natural Oak	FC.MB.916.NO
Golden Oak	FC.MB.916.GO
Renaissance Oak	FC.MB.916.RN
Picked Oak	FC.MB.916.PO
Rosewood Oak	FC.MB.916.SO
Medium Oak	FC.MB.916.MO
Light Oak	FC.MB.916.LO

Hardrock Maple	FC.MB.916.HM
Manitoba Maple	FC.MB.916.MM
White Washed Maple	FC.MB.916.WW
Light Maple	FC.MB.916.LM
Clear Maple	FC.MB.916.CM

Natural Cherry	FC.MB.916.NC
Select Cherry	FC.MB.916.SC
Medium Cherry	FC.MB.916.MC
Bourbon Cherry	FC.MB.916.BC
Golden Cherry	FC.MB.916.GC
Dark Cherry	FC.MB.916.DC
Heritage Cherry	FC.MB.916.HC
Auburn Cherry	FC.MB.916.AC

Red Mahogany	FC.MB.916.RM
Dark Red Mahogany	FC.MB.916.DM
Traditional Mahogany	FC.MB.916.TM

Presidential Walnut	FC.MB.916.PW
Imperial Walnut	FC.MB.916.IW
Mahogany On Walnut	FC.MB.916.MW

Knotty Pine	FC.MB.916.KP
-------------	--------------

All above items are \$9.00 a box

PVC Solids-Colors Standard Pk.

Color	20 Sheets per Box
White	FC.SP.916.WH
Almond	FC.SP.916.AL
Black	FC.SP.916.BL
Folkstone Gray	FC.SP.916.LG

All above items are \$29.00 a box

Unfinished Real Wood

Color	Item
Red Oak	FC.MB.916.RO
White Oak	FC.MB.916.WO
Maple	FC.MB.916.MP
Cherry	FC.MB.916.CH
Mahogany	FC.MB.916.MG
Pine	FC.MB.916.PN
White Birch	FC.MB.916.WB
Natural Birch	FC.MB.916.NB
Walnut	FC.MB.916.WA
Ash	FC.MB.916.AS

All above items are \$18.00 a box

Finished Real Wood

Color	Item
Red Oak	FC.MB.916.PRO
White Oak	FC.MB.916.PWO
Maple	FC.MB.916.PMP
Cherry	FC.MB.916.PCH
Mahogany	FC.MB.916.PMG
Yellow Pine	FC.MB.916.PYP
Birch	FC.MB.916.PWB
Walnut	FC.MB.916.PWA
Anigre	FC.MB.916.PAN
Ash	FC.MB.916.PAS
Sapele	FC.MB.916.PSP
Teak	FC.MB.916.PTK

All above items are \$21.00 a box

Dagger Joining Device

- Rapid on-the-job assembling or demounting without screws or tools of any kind
- Pre-mount plastic blocks to panels
- To join, simply insert steel dagger down into fastener for secure fit



Item	Price each	
	1-99	100+
DS8514S	\$1.86	Call

Cam Fitting

- Decorative connecting fittings for positive connections of panels and sides.
- The fitting is pressed into double holes with a drilling distance of 32 mm. 20 mm and 10 mm diameter insertion drilling holes. The panel can be inserted from above.

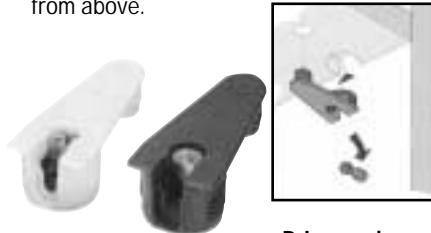

Color	Item	Price each		
		1-99	100-299	300+
White	1019484	\$1.29	\$.75	Call
Brown	1019693	1.29	.75	Call

Metal Connecting Screws

- Flat head
- 8mm diameter
- Nickel finish
- Sold per box of 100



For 2 Panels	Item	Price each		
		100-900	1000-1900	2000+
$\frac{1}{2}$ " thick	US555NP24	\$.44	\$.34	Call
$\frac{5}{8}$ " thick	US555NP31	.47	.37	Call
$\frac{3}{4}$ " thick	US555NP38	.50	.40	Call

LOK-LEVEL Double Action Joint Fastener

- Clamps edges flush & levels adjoining surfaces.
- Set screws compensate for different thicknesses of material & for warpage.
- $\frac{3}{4}$ " x 2 $\frac{1}{2}$ "

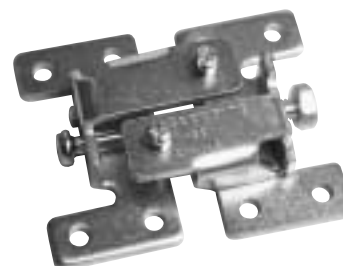

Item	Price each		
	1-99	100-199	200+
DS85105	\$4.99	\$3.87	Call

- Check out Casters, Glides & Levelers
- Check out Door Closers & Exit Hardware

Machine Screws

- #8-32 threading
- Truss heads

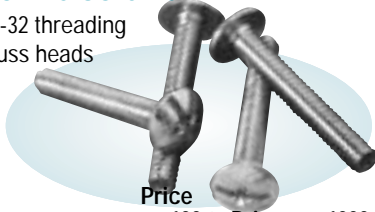

Size	Item	Price per 100	Price per 1000	
		100-900	1000-4900	Full Case
1/2"	TRUS812	\$2.18	\$5.29	Call
3/4"	TRUS834	2.32	5.86	Call
7/8"	TRUS878	2.56	6.46	Call
1"	TRUS81	2.80	7.04	Call
1 1/4"	TRUS8114	3.60	9.08	Call
1 1/2"	TRUS8112	3.84	9.68	Call
1 3/4"	TRUS8134	4.44	11.15	Call
2"	TRUS82	4.92	12.32	Call
2 1/4"	TRUS8214	7.48	18.76	Call
2 1/2"	TRUS8212	7.98	19.93	Call
BREAKAWAY				
1 3/4"	TRUS8134B	6.00	28.92	Call
1 3/4"	HF02235887*	6.50	35.00	

- Breakaway Screw can be clipped to fit almost any size drawer thickness
- Breaks at 3/4", 1", 1 1/4" & 1 1/2"
- *Metric Screw M4 threads, breaks at 3/4"

Screwdriver Bits



Style	Point Size	O.A.L.	Item	Price each		
				1-49	50-199	200+
Phillips	1	1"	AP4401	\$1.49	\$1.09	Call
Phillips	2	1"	AP4402	1.49	1.09	Call
Phillips	3	1"	AP4403	1.49	1.09	Call
Phillips	1	1"	AP4461	1.49	1.09	Call
Phillips	2	1"	AP4462	1.49	1.09	Call
Phillips	1	1 15/16"	AP491	1.49	1.09	Call
Phillips	2	1 15/16"	AP492	1.49	1.09	Call
Phillips	2	1 15/16"	AP492A	1.49	1.18	Call
Phillips	2	3 1/2"	AP492B	1.49	1.43	Call
Phillips	2	3 1/2"	AP492C	3.58	3.13	Call
Phillips	3	1 15/16"	AP493	2.10	1.84	Call
Phillips	3	1 15/16"	AP493A	2.31	2.02	Call
Phillips	3	3 1/2"	AP493B	2.66	2.32	Call

Square 5,6,7	1"	AP9501	1.49	1.09	.58
Square 8,9,10	1"	AP9502	1.49	1.09	.58

Driver Bit Holder



Item	Prices each		
	1-5	6-9	10+
APM490	\$12.20	\$11.05	\$9.54

Carriage Bolts

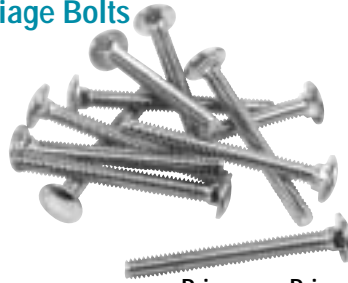

Size	Item	Price per 100	Price per 1000
		100-900	1000+
1/4" x 1 1/2"	CAR14-112	\$12.99	\$57.60
1/4" x 2"	CAR14-2	12.99	58.62
1/4" x 2 1/2"	CAR14-212	12.99	68.42
1/4" x 3"	CAR14-3	12.99	80.50
1/4" x 3 1/2"	CAR14-312	12.99	87.50
5/16" x 1 1/2"	CAR516-112	12.99	75.80
5/16" x 2"	CAR516-2	12.99	89.60

Nuts



Size	Item	Price per 100	Price per 1000
		100-900	1000+
10/24	NUTS1024	\$2.99	\$14.20
6/32	NUTS632	8.22	55.10
8/32	NUTS832	4.18	27.50
10/32	NUTS1032	5.11	32.70
1/4"	NUTS14	9.71	73.50
5/16"	NUTS516	12.56	90.50
3/8"	NUTS38	14.71	119.40

Lockwashers



Size	Item	Price per 100		
		100-300	400-900	1000+
1/4"	LW14	\$1.49	\$.99	Call
5/16"	LW516	1.34	1.17	Call
3/8"	LW38	2.04	1.78	Call
1/2"	LW12	3.88	3.39	Call
#6	LW6	1.49	.99	Call
#8	LW8	1.49	.99	Call

Title Joint Fasteners

- Zinc finish
- Flat bar dim. 7/16" x 3/16" x 1"

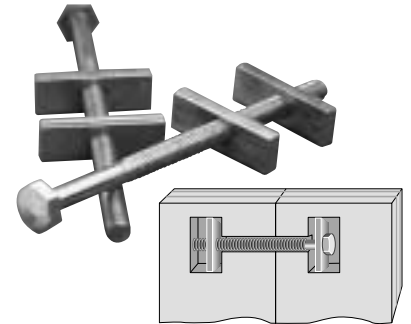

Length	Item	Price each		
		1-99	100-299	300+
3 1/2"	517-ZC	\$1.49	\$.99	call
4	513-ZC	1.49	.99	call

Title Joint Fasteners

- Designed for 3/4" thick wood.
- Center to center 2" to 3 1/2"
- Use 7/8" flat drill bit

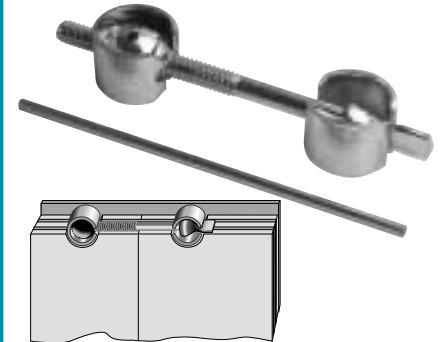

Length	Item	Price each		
		1-99	100-199	200+
3 1/2"	516/100-ZC	\$2.19	\$1.76	Call

Decorative Washer



Size	Item	Price per 1000	
		1000-9000	Full Case
#6	CWS6	\$12.17	Call
#8	CWS8	13.09	Call



Corner Braces

- Reinforces right angle corner joints
- Rust resistant
- Screws not included



Size	# of Screw Holes		Item	Price each	
	Size	Size		1-199	200+
1" x 1" x 1/2"	2	#6	FE2261	\$1.09	Call
1 1/2" x 1 1/2" x 1/2"	4	#6	FE22615	1.09	Call
2" x 2" x 5/8"	4	#6	FE2262	1.19	Call
2 1/2" x 2 1/2" x 5/8"	4	#6	FE22625	1.29	Call
3" x 3" x 3/4"	4	#8	FE2263	1.39	Call
4" x 4" x 7/8"	4	#8	FE2264	1.59	Call
5" x 5" x 1"	6	#10	FE2265	2.24	Call
6" x 6" x 1 1/8"	6	#8/#10	FE2266	3.28	Call

Mending Plate

- Reinforces joints, seams, and cracks
- Rust resistant
- Screws not included



Size	# of Screw Holes		Item	Price each	
	Size	Size		1-199	200+
2" x 5/8"	2	#5/#6	FE2252	\$.99	Call
2 1/2" x 5/8"	2	#6	FE22525	1.29	Call
3" x 3/4"	4	#6/#8	FE2253	1.49	Call
4" x 7/8"	4	#6/#8	FE2254	1.75	Call
5" x 1"	4	#8	FE2255	2.00	Call
6" x 1 1/8"	4	#10	FE2256	2.50	Call
8" x 1 1/4"	4	#8	FE2258	2.95	Call

Joining Biscuits

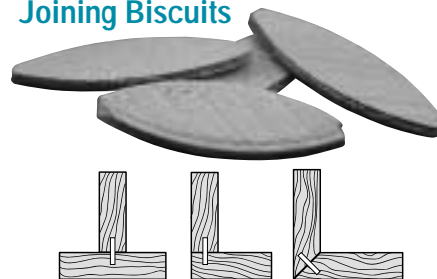

Ideal for Miter Joining or Surface-To-Surface joining

Size	Item	Price each	
		1-9 boxes	10+ boxes
0 (1 3/4" x 5/8")	5551	\$39.00	\$34.50
10 (2 1/8" x 3/4")	5552		
20 (2 3/8" x 1")	5553		
Sold per box/1000 per box			

Flat Toggle Bolts

- Use in: Block, wallboard, plaster, hollow tile

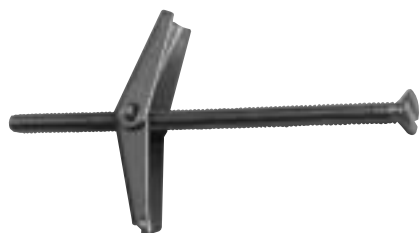

Size	Item	Price per 100	
		100-500	600+
3/16" x 3"	UFTB3316	\$18.90	Call
3/16" x 4"	UFTB4316	20.34	Call
1/4" x 3"	UFTB7314	22.65	Call
1/4" x 4"	UFTB7414	27.48	Call

Plastic Toggles

- Use in: wallboard, solid masonry or hollow doors
- Sold in boxes of 100 only

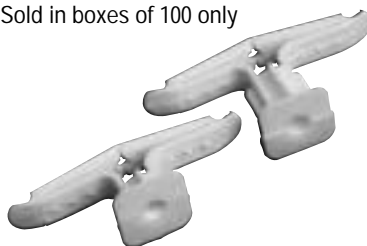

Size	Item	Price each	
		100-900	1000+
3/8" x 1/2"	MCTB100C	\$.13	Call
5/8" x 3/4"	MCTC100C	.15	Call

Drywall Anchors

- Fast: no predrilling
- Easy: install with #2 Phillips screwdriver (unscrews from drywall)
- Secure: deep threads lock into 3/8", 1/2", & 5/8" drywall

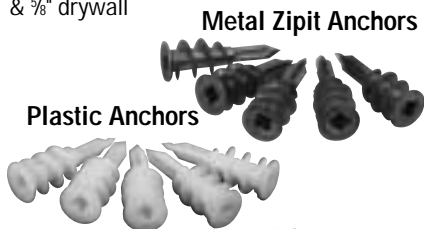

Material	Item	Price per 100	
		100-900	1000+
Metal Zipit*	RP2346	\$19.75	Call
Plastic*	RP2345	14.75	Call

*use #8 sheet metal screws.

Drawer Front Adjusters

- Attaches drawer front to four sided drawer box with wood screw
- Allows side and height realignment of front

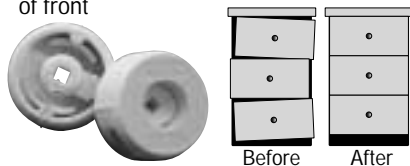

GRASS

Item	Prices each		
	100-299	300-499	500+
00393	\$.25	\$.21	Call

Uses 8 x 32 machine screw (not included)

Spiral Dowel Pins

- Beech

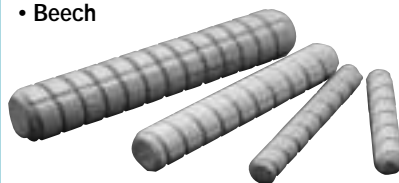

Dia./Length	Item	Price per 100		
		100-400	500-900	1000+
1/4" x 1 1/2"	HV14112	\$1.99	\$1.79	Call
1/4" x 2"	HV142	2.08	1.88	Call
3/8" x 1 1/2"	HV38112	1.86	1.68	Call
3/8" x 2"	HV382	2.41	2.17	Call
3/8" x 2 1/2"	HV38212	2.89	2.61	Call
3/8" x 3"	HV383	3.04	2.71	Call

3/6" Wooden Dowel Sticks

- Beech

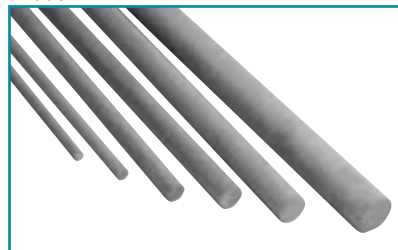

Dia.	Item	Price each		
		1-49	50-99	100+
1/4"	HV1436	\$2.43	\$1.79	Call
5/16"	HV51636	2.43	1.79	Call
3/8"	HV3836	2.43	1.79	Call
7/16"	HV71636	2.43	1.79	Call
1/2"	HV1236	2.43	1.79	Call

- Check out **Functional Cabinet Hardware**
- Check out **Table Hardware**

Drill Bits

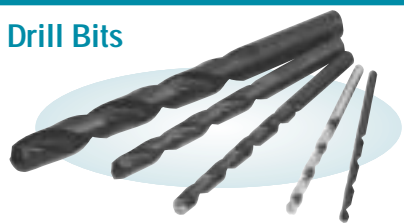

Size	Item	Price Each	
		1-11	12+
1/16"	DB116	1.02	.85
5/64"	DB564	1.02	.85
3/32"	DB332	1.02	.85
7/64"	DB764	1.06	.89
1/8"	DB18	1.06	.89
9/64"	DB964	1.14	.94
5/32"	DB532	1.21	.99
11/64"	DB1164	1.24	1.03
13/64"	DB316	1.27	1.08
13/64"	DB1364	1.41	1.28
7/32"	DB732	1.63	1.43
15/64"	DB1564	1.71	1.47
1/4"	DB14	1.90	1.72
17/64"	DB1764	2.11	1.86
9/32"	DB932	2.26	1.97
5/16"	DB516	2.90	2.60
21/64"	DB2164	5.87	5.31
3/8"	DB38	4.60	4.04
25/64"	DB2564	5.03	4.48
7/16"	DB716	5.80	5.23
1/2" x 3/8"	DB12	9.84	8.92
3/32" Brad Point 1/4" eyelets	AT606-128	6.90	4.80
13 piece set			
1/16" to 1/4" by 64ths. Includes metal index.	DB13C	17.74	15.52

Jig Saw Blades



WOOD CUTTING BLADES		Price per 5pk	
Usage	TPI Item	1-9	10+
Fine finish	20 BHT101AO	\$12.17	Call
clean cut	10 BHT101B	9.43	Call
down cut	10 BHT101BR	10.57	Call
fast cut	6 BHT101D	9.43	Call
rough cut	6 BHT144D	9.60	Call
rough cut	8 BHT111C	5.98	Call
rough cut	6 BHT244D	10.33	Call
Price per 100pk			
rough cut	6 BHT144D100	145.75	Call
fast cut	6 BHT101D100	143.00	Call
clean cut	10 BHT101B100	143.00	Call

METAL CUTTING BLADES		Price per 5pk	
Cuts	TPI Item	1-9	10+
Aluminum	14 BHT101A	\$15.88	Call
1/8" T Steel	24 BHT118A	8.22	Call
1/4" T Steel	14 BHT118B	8.22	Call
1/8" T Steel	36 BHT118G	8.22	Call
1/4" T Steel	8 BHT127D	9.92	Call
non-ferrous	8 BHT111C	5.98	Call
Mild Steel	8 BHT227D	10.85	Call
1/8" T Steel	24 BHT318A	15.30	Call
1/4" T Steel	14 BHT318B	15.30	Call

Hole Saw

Cuts holes in Wood, Plastic, & Metal

- Top quality designed for smooth, fast, cutting and long life.
- 1 1/2" Cutting Depth
- *Requires separate Arbor (HSM35PS)



Dia.	Item	Price each	
		1-4	5+
1 1/8"	HS178	\$10.01	Call
2 3/8"	HS238	12.41	Call
3 1/8"	HS318	13.73	Call
2 1/2"	HS218	12.01	Call

Hole Saw Arbor

Allows 1 1/2" to 6" hole saws to fit 3/8" drills.

- Quick change pin drive design.

HSM35PS \$15.00 ea.



Speedbors



Dia.	Item	Price each	
		1-9	10+
3/8"	AT-604-200	2.04	Call
1/2"	AT-604-250	2.22	Call
5/8"	AT-604-270	2.22	Call
3/4"	AT-604-400	2.64	Call
7/8"	AT-604-500	2.70	Call
1"	AT-604-600	3.12	Call
1 1/4"	AT-604-700	3.78	Call

Self-Centering Drill Bit

- Accurately center drilling holes for Hinges, Strike Plates Door Butts, and all hardware using screws.
- 1/4" shank



Bit	Item	Price each	
		1-9	10+
7/64", #5	DS95-325	\$12.00	Call
9/64", #9	DS95-326	13.94	Call

Steel Hand-Scrapers

- Contains three scrapers: one each of three different thicknesses.
- Used for wood & glue scraping
- Can be sharpened by using a hard steel burnisher on the edges
- 5" x 3"



Item	1-9	10+
AT4010	\$6.95	\$5.90

Carbide-Tipped Laminate Cutter

- A precision cutting tool made with perfectly ground carbide edges for fast, accurate cutting & scoring of laminates, plastics, Plexiglas® & other materials.
- Tool features lightweight steel construction, special "safety-grip" plastic coated handle, and carbide-tips that can be re-sharpened.
- Quality craftsmanship in your work requires the highest quality in hand tools.



Item	1-9	10+
AT20003	\$12.10	\$9.99



Cut-Off & Cross-Cut Saws

10° Hook, Alternate Top Bevel (ATB) Grind

Application: General cut-off, cross-cutting and trimming of natural woods.

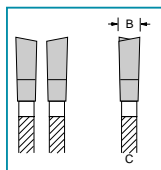
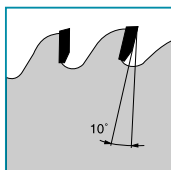

Dia.		Kerf		Plate		Item	1-9	10+
Inch	Teeth	Inch	Inch	Inch	Bore			
12	60	.126	.087	1	AT612600	\$127.50	\$105.19	
12	72	.126	.087	1	AT612720	143.20	118.14	
14	72	.137	.098	1	AT614720	156.40	129.03	
14	84	.137	.098	1	AT614840	179.80	148.34	

Trim Saws 8" to 18"

10° Hook

Triple Chip (TC) Grind

Application: Trimming, and single or double-sided veneered and plastic laminated panels.

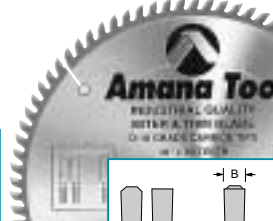
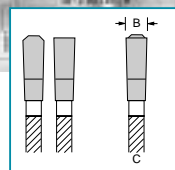
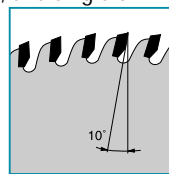

Dia.		Kerf		Plate		Item	1-9	10+
Inch	Teeth	Inch	Inch	Bore				
10	80	.126	.087	5/8	AT610801	\$135.40	\$111.71	
14	108	.137	.098	1	AT614109	207.00	170.78	

Cut-Off & Cross-Cut Saws

8" to 20"

10° Hook, Triple Chip (TC) Grind

Application: General trimming and cross-cutting of natural woods, plywood, composition material and single or double-sided plastic laminated material.

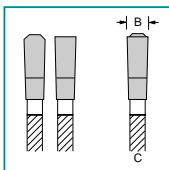
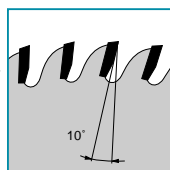

Dia.		Kerf		Plate		Item	1-9	10+
Inch	Teeth	Inch	Inch	Bore				
10	60	.126	.087	5/8	AT610601	\$100.45	\$82.87	
12	72	.126	.087	1	AT612601	137.90	113.77	
12	72	.126	.087	1	AT612721	153.40	126.56	
14	72	.137	.098	1	AT614721	170.85	140.95	
14	84	.137	.098	1	AT614841	196.10	161.78	

Combination Ripping & Cross-Cut Saws

10° Hook

Combination Grind

4ATB & raker

Application: Designed for ripping and cross-cutting natural woods.

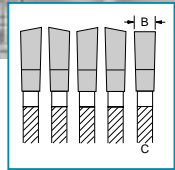
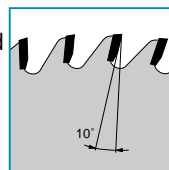

Dia.		Kerf		Plate		Item	1-9	10+
Inch	Teeth	Inch	Inch	Bore				
10	50	.135	.095	5/8	AT610504	\$92.05	\$75.94	

Melamine Saws

8" to 16"

6° Negative Hook, 25° 'High-ATB' Grind

Application: Designed to cut melamine chip-free on both sides. Easily resharpened.

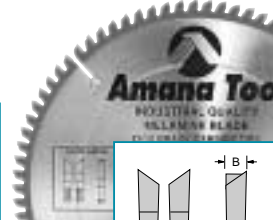
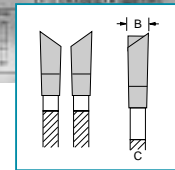
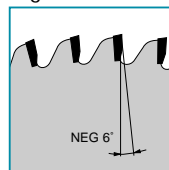

Dia.		Kerf		Plate		Item	1-9	10+
Inch	Teeth	Inch	Inch	Bore				
10	80	.126	.102	5/8	ATMB10800	\$145.70	120.20	
12	96	.126	.102	1	ATMB12960	178.30	147.10	

Trim Saws 7" to 18"

10° Hook

Alternate Top Bevel (ATB) Grind

Application: Trim and size veneers and laminates in single sheets or stacks. Also for wood-veneered laminated panels.

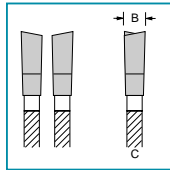
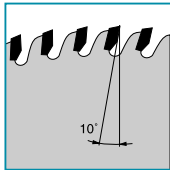

Dia.		Kerf		Plate		Item	1-9	10+
Inch	Teeth	Inch	Inch	Bore				
10	80	.126	.087	5/8	AT610800	\$125.90	103.87	
14	108	.137	.098	1	AT614108	192.60	158.90	

'EURO-RIP' Ripping Saw with Cooling Slots and Anti-Kickback Feature 10" to 14"

18° Hook

Flat Top (FT) Grind

Application: Ripping natural woods, along the grain. Anti-kickback.

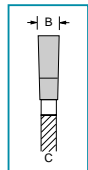
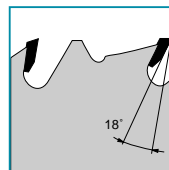

Dia.		Kerf		Plate		Item	1-9	10+
Inch	Teeth	Inch	Inch	Bore				
10	20	.126	.087	5/8	ATRB1020	\$84.20	\$69.47	

- Check out Slides & Swivels
- Check out Cabinet Hinges

Boring / Drilling Tools Carbide-Tipped Countersinks

- 2-Wing for Wood Screws
- Maximum 3/8" Depth of Cut

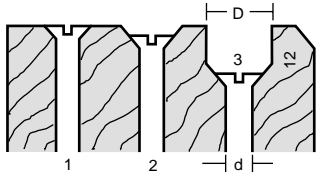

Suggested Wood Screw size	Accepts *Drill Dia.	'D' Countersink Dia.	'd' Shank Dia.	Replacement		Price each	
				Drill Bit	Item	1-9	10+
#2	3/32	11/32	5/16	630-002	AT55200	\$25.80	\$21.29
#4	1/8	3/8	5/16	630-102	AT55202	25.80	21.29
#6	9/64	25/64	5/16	630-802	AT55204	25.70	21.20
#8	5/32	13/32	5/16	630-202	AT55206	27.30	22.52
#8-#9	11/64	7/16	5/16	630-302	AT55208	27.95	23.06
#10	3/16	29/64	3/8	630-402	AT55210	28.60	23.60
#14-#16	1/4	17/32	3/8	630-702	AT55216	31.30	25.82

SupeRabbet® Bit

2 Flute With Ball Bearing Guide

- Shank Dia. 1/2"
- An ingenious rabbeting bit that will enable rabbet cuts from 1/16" through 3/4" in 1/16" increments, and five undersized plywood sizes, using optional collars. Particularly useful when working with large stock, or when a precise rabbet depth is required (ie. 23/32" depth for plywood). Supplied with a 2" diameter rabbet bit, hex key, instructions and all necessary parts for 5/8" and 3/4" depth rabbets.



Cutting Length	Large Dia.	OAL*	Item	Price each	
				1-9	10+
7/8"	2"	3"	AT49360	\$82.95	\$68.43

Accessory Collar Kit

5-piece kit for 1/16", 1/8", 1/4", 3/8", 1/2" depth rabbets
AT67500 \$39.70 \$32.75



NOTE: 5/8" and 3/4" depth is standard width 49360.

Router Arbors With Hex Nut and Washers

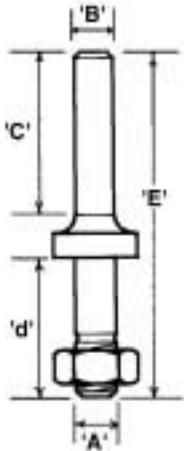

'A' Thread Dia.	'B' Shank Dia.	'C' Shank Length	'D' Arbor Length	'E' Overall Length	Item	Application
5/16-24 NF	1/4	1 1/4	7/8	2 3/8	AT47600	2 & 3-Wing slotting assemblies, and single 4-wing trim cutter assemblies.
5/16-24 NF	1/2	1 1/2	7/8	2 3/8	AT47604	
1/4-28 NF	1/4	1 1/8	1/4	1 13/16	AT47611*	Screw type mortising bits 55258.

*Due to application, these arbors are not furnished with hex nut or washers.

Price each

1-9	10+
\$4.20	\$3.47
*4.00	3.30

Forstner Pattern Bits

- 2 Wing
- High Carbon Tool Steel
- Shank 3/8"
- Overall length 3 1/2"

Application:

Drill pocket-holes, flatbottom holes using any 3/8" or larger portable drill or stationary drill press.
(A small pilot hole used for centering will be present on flat bottom holes)



Dia.	Item	Price each	
		1-9	10+
1/2	ATFO-127	\$13.50	\$11.14
5/8	ATFO-160	14.00	11.55
3/4	ATFO-190	15.15	12.50
7/8	ATFO-222	15.70	12.95
1	ATFO-254	16.25	13.41
1 1/8	ATFO-285	17.00	14.03
1 1/4	ATFO-317	18.10	14.93
1 3/8	ATFO-349	20.80	17.16
35mm	ATFO-350	18.95	15.63
1 1/2	ATFO-381	21.35	17.61
1 5/8	ATFO-413	24.60	20.30
1 3/4	ATFO-445	30.00	24.75
1 7/8	ATFO-476	31.10	25.66
2	ATFO-508	31.30	25.82
2 1/8	ATFO-540	33.25	27.43

Hinge Boring Bits

- 2-Wing with Spurs
- 57mm OA length
- 10mm Shank
- Right Handed
- Drill presses use EB-351



See Cabinet hinges

Dia.	Item	Price each	
		1-9	10+
35mm	AT203351	\$39.10	Call
40mm	AT203401	49.40	Call
8mm*	AT301008	17.70	Call

*Left handed



* OAL-Overall Length

Straight Plunge Cutting Bits

3/8" Shank • Single Flute



Cut Dia.		Cut Ht.	OAL*	Item	Price each	
					1-9	10+
3/8	1	2 1/2		AT45300	\$16.65	\$13.74

1/2" Shank • Single Flute



Cut Dia.		Cut Ht.	OAL*	Item	Price each	
					1-9	10+
3/8	1	2 3/4		AT45302	\$16.75	\$13.82
1/4	3/4	2 1/2		AT45304	18.25	15.06
1/2	1 1/4	2 7/8		AT45308	16.65	13.74
1/2	1 1/2	3 1/8		AT45310	18.35	15.14
1/2	2	4 1/4		AT45312	23.30	19.22
9/16	1 1/4	2 7/8		AT45314	19.65	16.21
5/8	1 1/4	2 7/8		AT45316	20.70	17.08

3/8" Shank • 2 Flute



Cut Dia.		Cut Ht.	OAL*	Item	Price each	
					1-9	10+
3/8	1	2 1/2		AT45402	\$16.70	\$13.78
3/8	1 1/4	2 3/4		AT45404	19.75	16.29
1/2	1	2 1/2		AT45406	18.30	15.10

1/2" Shank • 2 Flute



Cut Dia.		Cut Ht.	OAL*	Item	Price each	
					1-9	10+
1/4	3/4	2 1/2		AT45408~	\$18.85	\$15.55
5/16	3/4	2 1/2		AT45410	17.45	14.40
5/16	1	2 3/4		AT45412	17.75	14.64
3/8	1	2 3/4		AT45414	17.45	14.40
7/16	1 1/4	3		AT45416	20.40	16.83
1/2	1	2 5/8		AT45418	17.45	14.40
1/2	1 1/4	2 7/8		AT45420	17.60	14.52
1/2	1 1/2	3 1/8		AT45422	18.60	15.35
1/2	1 1/2	4 1/4		AT45424	23.20	19.14
1/2	2	4 1/4		AT45426	24.10	19.88
1/2	2 1/2	4 1/2		AT45427†	33.20	27.39
9/16	1 1/4	2 7/8		AT45428	20.90	17.24
5/8	1	2 5/8		AT45430	20.80	17.16
5/8	1 1/4	2 7/8		AT45432	21.95	18.11
5/8	1 1/2	3 1/8		AT45434	24.70	20.38
1 1/16	1 1/4	2 7/8		AT45436	24.45	20.17
3/4	1	2 5/8		AT45438	23.50	29.39
3/4	1 1/4	2 7/8		AT45440	23.25	19.18
3/4	1 1/2	3 1/8		AT45442	26.05	21.49
1 3/16	1 1/4	2 7/8		AT45444	26.15	21.57
7/8	1 1/4	2 7/8		AT45446	26.80	22.11
1	1 1/4	2 7/8		AT45448	28.05	23.14
1 1/4	1 1/4	2 7/8		AT45450	36.20	29.87
1 1/2	1 1/4	2 7/8		AT45452	43.70	36.05

~With solid carbide cutting edge.
†Not guaranteed due to extreme length.

1/4" Shank • 2 Flute



∞Not guaranteed due to extreme dia.
-With solid carbide cutting edge.
‡Not guaranteed due to extreme length.

Cut Dia.		Cut Ht.	OAL*	Item	Price each	
					1-9	10+
1/8	7/16	2		AT45200~∞	\$14.35	\$11.84
3/16	7/16	2		AT45202~	15.45	12.75
1/4	1/2	2		AT45204	14.25	11.76
1/4	3/4	2		AT45208	14.50	11.96
1/4	1	2 1/4		AT45210	15.05	12.42
1/4	1	2 7/8		AT45211‡	17.55	14.48
9/32	1	2 1/4		AT45212	16.65	13.74
5/16	1	2 1/4		AT45214	15.65	12.91
3/8	3/4	2		AT45216	15.70	12.95
3/8	1	2 1/4		AT45218	16.60	13.70
3/8	1 1/4	2 1/2		AT45220	19.45	16.05
7/16	1	2 7/8		AT45222	18.85	15.55
1/2	3/4	1 3/4		AT45224	16.70	13.78
1/2	1	2 1/8		AT45226	17.75	14.64
9/16	3/4	2 1/8		AT45227	17.80	14.69
5/8	3/4	2		AT45228	18.60	15.35
3/4	3/4	2		AT45230	20.50	16.91
3/4	3/4	2		AT45232	23.20	19.14

Mortising Bits

- 2 Flute
- Shank dia. 1/4"
- Cutting length 3/4"
- Overall length 2"

NOTE: A proper mortising bit, as shown, should have a large gullet between the two flutes, indicated with an arrow.

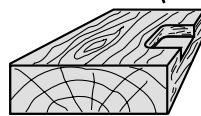

• 2 Flute • Screw Type
Cutters Only (1/4" - 28 Thread)
Fits Porter-Cable & other standard
model mortising jigs.
Also used in door machines.

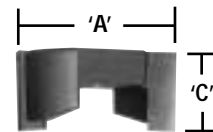

Cut Dia.		Item	Price each	
			1-9	10+
1/2		AT45500	\$16.05	\$13.24
5/8		AT45502	18.60	15.35
3/4		AT45504	19.75	16.29

Cut Dia.		Cut Ht.	Item	Price each	
				1-9	10+
7/8	1/2		AT55252	\$33.10	\$27.31
1	1/2		AT55254	34.25	28.26
1 1/8	9/16		AT55256	35.65	29.41
1 1/4	5/8		AT55258	25.80	21.29

- Check out Production & Finishing Materials
- Check out Storage & Convenience

* OAL-Overall Length

Stagger Tooth Plunge Cutting Bits



Cut Dia.	Cut Ht.	Shank Dia.	OAL*	Item	Price each	
					1-9	10+
1/4	1	1/4	2 1/4	AT51300	\$17.60	\$14.52
1/2	2	1/2	4 1/4	AT51308	25.45	21.00

Panel Pilot Bits

Single Flute

Application:

Designed for the mobile home and R. V. industries, for fast cut out work.

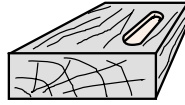

Cut Dia.	Cut Ht.	Shank Dia.	OAL*	Item	Price each	
					1-9	10+
1/4	3/4	1/4	2 1/2	AT45506	\$12.30	\$10.15
1/2	1 1/4	1/2	3 1/2	AT45510	18.50	15.26

NO-FILE™ BITS

With Ball Bearing Guide

US Patent NO. 4,669,923

Amana's new patented "No-File"™ Bit eliminates hand filing of laminates that normally follows trimming. These specially designed tools will flush trim the laminate and "break" the sharp edge all in one pass.

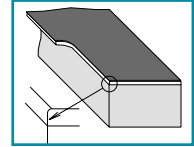

Cut Dia.	Cut Ht.	Shank Dia.	OAL*	Item	Price each	
					1-9	10+
5/8	3/8	1/4	1 7/8	AT47150	\$29.20	\$24.09
5/8	3/8	1/2	2 7/8	AT47152	29.70	24.50

Flush Trim Plunge Bits With Upper Ball Bearing

• 2 Flute

Very useful for template and pattern routing where the template is on top of the workplace.

Ball bearing guide rides against the template for an exact duplication. If used on a router table, the pattern will be on the bottom, below the workplace.

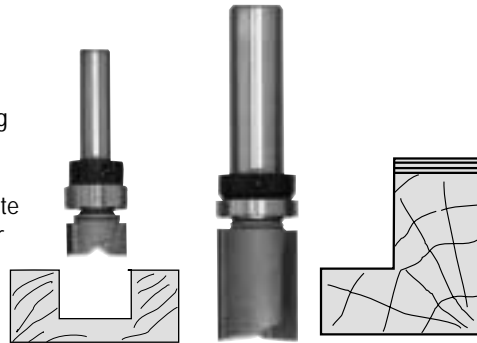

Cut Dia.	Cut Ht.	Shank Dia.	OAL*	Item	Price each	
					1-9	10+
1/2	1	1/4	2 1/2	AT45460	\$27.75	\$22.89
5/8	1	1/4	2 3/4	AT45462	28.80	23.76
3/4	1	1/4	2 1/2	AT45464	29.95	24.71
1	1	3/8	2 7/8	AT45466	38.45	31.72

Rabbeting Bits

- 2 Flute With Ball Bearing
- Guide Depth of Rabbet 3/8"
- Cutting length 1/2"

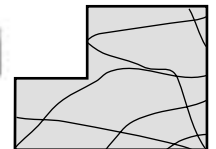

Cut Dia.	Shank Dia.	OAL*	Item	Price each	
				1-9	10+
1/4	1/4	2	AT49300	\$31.15	\$25.70
1/4	1/2	2 3/8	AT49302	32.95	27.18

Flush Trim Plunge Bits With Ball Bearing Guide

• 2 Flute

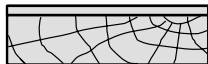

With Ball Bearing Guide

• 3 Flute



Cut Dia.	Cut Ht.	Shank Dia.	OAL*	Item	Price each	
					1-9	10+
3/8	1	1/4	2 5/8	AT47100	\$17.60	\$14.52
3/8	1/2	1/4	2 1/8	AT47102	17.35	14.31
1/2	1	1/4	2 5/8	AT47104	17.10	14.11
1/2	1/2	1/4	2 1/4	AT47106	16.85	13.90
1/2	1	1/2	3 1/4	AT47108	19.50	16.09
1/2	1/2	1/2	2 3/4	AT47110	19.70	16.25
1/2	1	3/8	2 7/8	AT47112	21.95	18.11

1/4" dia. for closer inside corner cutting.

Cut Dia.	Cut Ht.	Shank Dia.	OAL*	Item	Price each	
					1-9	10+
1/2	1	1/4	2 5/8	AT47114	\$23.40	\$19.31
1/2	1/2	1/4	2	AT47116	24.40	20.13
1/2	1	1/2	3	AT47118	26.05	21.49
1/2	1/2	1/2	2 5/8	AT47120	25.85	21.33

Replacement bearing AT47706 - \$3.75 \$3.09

Flush Trim 'V' Groove Bits

- 2 Flute With Ball Bearing Guide
- Shank dia. 1/2"

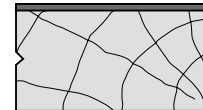

Cut Dia.	Cut Ht.	OAL*	Item	Price each	
				1-9	10+
5/8	1	3	AT47162	\$33.20	\$27.39

Replacement bearing AT47706 3.75 3.09



* OAL-Overall Length

Flush Trim Bits

Extra Long With
Ball Bearing Guide

- 2 Flute
- Shank dia. 1/2"

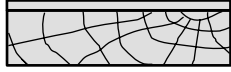

- 3 Flute
- Shank dia. 1/2"



Cut Dia.	Cut Ht.	OAL*	Item	Price each	
				1-9	10+
1/2	1 1/2	3 7/8	AT47124	\$29.10	\$24.01
1/2	2	4 1/4	AT47126	30.95	25.53
1/2	1 1/2	3 3/4	AT47124-2**	43.35	35.76
1/2	2	4 1/4	AT47126-2**	52.25	43.11

Cut Dia.	Cut Ht.	OAL*	Item	Price each	
				1-9	10+
1/2	1 1/2	3 7/8	AT47128	\$38.45	\$31.72
1/2	1 1/2	3 3/4	AT47128-2**	55.75	45.99

** Denotes double ball bearing for added stability.
Replacement bearing AT47706- \$3.75 \$3.09

Bevel Trim Bits

- 2 Flute With Ball Bearing Guide
- Shank dia. 1/4"

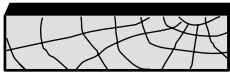

- 3 Flute With Ball Bearing Guide
- Shank dia. 1/4"



Bevel Degree	Carbide Height	OAL*	Item	Price each	
				1-9	10+
15°	3/32	1 7/8	AT47200	\$20.90	\$17.24
25°	3/32	1 7/8	AT47202	21.35	17.61
45°	1/4	1 7/8	AT47204	24.95	20.58

Bevel Degree	Carbide Height	OAL*	Item	Price each	
				1-9	10+
23°	7/16	1 7/8	AT47300	\$28.35	\$23.39
7°	7/16	2	AT47302	30.10	24.83

Slotting Cutter Assemblies 2 & 3 Wing, 1/2" Depth of Cut

- 1 7/8" Diameter
- 2 1/8" Overall Length
- 1/4" Shank

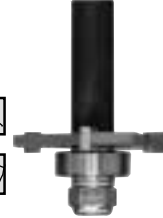
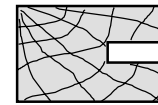

2 Wing

Kerf	Item	Price each	
		1-9	10+
1/8	AT53306	\$24.70	\$20.38
3/16	AT53308	25.05	20.67
1/4	AT53310	25.50	21.04

3 Wing

Kerf	Item	Price each	
		1-9	10+
1/16	AT53400	\$25.30	\$20.87
5/64	AT53402	25.65	21.16
3/32	AT53404	25.90	21.37
1/8	AT53406	27.50	22.69
*3/32	AT53407	28.20	23.27
3/16	AT53408	28.20	23.27
1/4	AT53410	28.30	23.35

NOTE: All above assemblies include cutter, arbor and ball bearing.
*3/32 size also used for 'biscuit-joint' cutting.

2 & 3 Wing Slotting Cutters

- Bore 5/16"

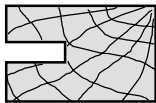

2 Wing

Kerf	Dia.	Item	Price each	
			1-9	10+
1/16	1 1/8	AT53100	\$15.15	\$12.50
5/64	1 1/8	AT53102	15.15	12.50
1/8	1 1/8	AT53106	16.05	13.24
3/16	1 1/8	AT53108	16.40	13.53



3 Wing

Kerf	Dia.	Item	Price each	
			1-9	10+
1/16	1 1/8	AT53200	\$17.30	\$14.27
5/64	1 1/8	AT53202	17.30	14.27
3/32	1 1/8	AT53204	17.80	14.69
1/8	1 1/8	AT53206	19.45	16.05
5/32	1 1/8	AT53207	20.10	16.58
3/16	1 1/8	AT53208	20.10	16.58
1/4	1 1/8	AT53210	20.40	16.83

Raised Panel Bits

- 2 Flute With Ball Bearing Guide
- Carbide height. 1/2"
- Shank dia. 1/2"
- Large dia. 3 3/8"

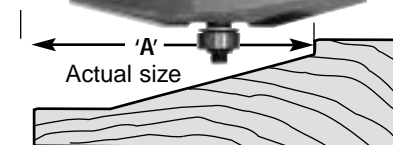

A' Degree	Angle	OAL	Item	Price each	
				1-9	10+
*1 1/16	15°	2 3/8	AT54117	\$152.15	\$125.52

NOTE: Reveal (**A') shown on above tool reflects the total length of cut. Therefore, you must deduct (usually 3/8") for allowing the panel to recess into the frame.

- Check out Casters, Glides & Levelers
- Check out Table Hardware

* OAL-Overall Length

Plunging Round-Over Bits

- 2 Flute
- Shank dia. 1/2"

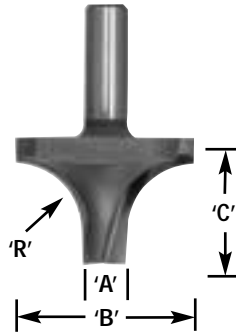
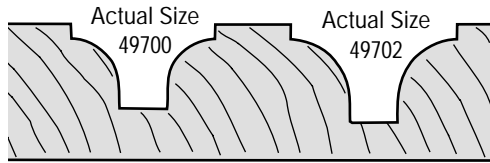

'R' Radius	'A' Sm. Dia.	'B' Lg. Dia.	'C' Carbide Height	OAL*	Item	Price each	
						1-9	10+
1/4	.240	3/4	1/2	2	AT49700	\$51.95	\$42.86
5/16	.245	7/8	9/16	2 1/16	AT49702	53.25	43.93
3/8	.250	1	5/8	2 1/8	AT49704	56.15	46.32
1/2	.363	1 3/8	1	2 1/2	AT49706	69.05	56.97
5/8	.500	1 1/4	1 1/4	2 3/4	AT49708	76.05	62.74
3/4	.500	2	1 1/8	2 5/8	AT49710	84.20	69.47

Corner Rounding Bits

- 2 Flute With Ball Bearing Guide

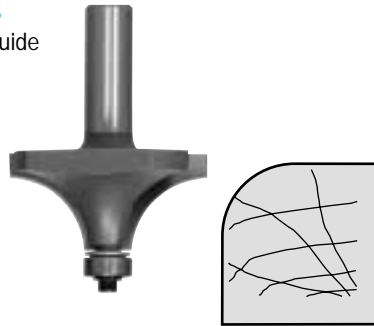

*Not guaranteed due to extreme diameter and radius.
For best results it is recommended to use a smaller radius bit or chamfer the material prior to using these large radius tools.
Tool life will be prolonged and a smoother finish will result.

Radius	Lg. Carbide Dia.	Shank Dia.	Shank Dia.	OAL*	Item	Price each	
		Ht.				1-9	10+
1/16	5/8	3/16	1/4	1 3/4	AT49492	\$34.25	\$28.26
1/8	5/8	5/16	1/2	2 1/4	AT49494	35.60	29.37
1/4	3/4	3/8	3/4	2	AT49496	32.85	27.10
3/8	3/4	3/8	1/2	2 5/16	AT49498	35.60	29.37
1/2	7/8	1/2	1/4	2	AT49500	33.45	27.60
3/4	7/8	1/2	1/2	2 1/16	AT49502	34.75	28.67
1	1	1/2	1/4	2	AT49504	33.20	27.39
1 1/4	1	1/2	1/2	2 1/16	AT49506	33.85	27.93
1 1/2	1 1/8	1/2	1/4	2 1/16	AT49508	35.60	29.37
1 3/4	1 1/4	5/8	1/4	2 3/16	AT49512	34.95	28.83
2	1 1/4	5/8	1/2	2 5/16	AT49514	36.15	29.82
2 1/4	1 1/2	3/4	1/4	2 1/4	AT49516	38.45	31.72
2 1/2	1 1/2	3/4	1/2	2 3/8	AT49518	39.65	32.71
2 3/4	1 3/4	7/8	1/2	2 3/4	AT49519	59.10	48.76
3	2	1	1/2	2 7/8	AT49520	62.85	51.85
3 1/4	2 1/2	1 1/4	1/2	3 1/16	AT49522*	125.75	103.74
3 1/2	3	1 1/2	1/2	3 1/4	AT49524*	173.20	142.89
3 3/4	3 1/2	1 3/4	1/2	3 3/8	AT49526*	195.65	161.41

Beading Bits

- 2 Flute With Ball Bearing Guide

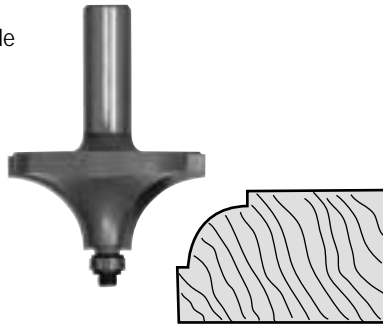

Radius	Lg. Carbide Dia.	Shank Dia.	Shank Dia.	OAL*	Item	Price each	
		Ht.				1-9	10+
1/8	3/4	3/8	1/4	2	AT49596	\$32.85	27.10
3/16	7/8	1/2	1/4	2	AT49600	33.45	27.60
1/4	7/8	1/2	1/2	2 1/16	AT49602	34.75	28.67
3/8	1	1/2	1/4	2	AT49604	33.20	27.39
1/2	1	1/2	1/2	2 1/16	AT49606	33.85	27.93
3/4	1 1/8	1/2	1/4	2 1/16	AT49608	35.60	29.37
1	1 1/8	1/2	1/2	2 1/16	AT49610	36.70	30.28
1 1/4	1 1/4	5/8	1/4	2 3/16	AT49612	34.95	28.83
1 1/2	1 1/4	5/8	1/2	2 5/16	AT49614	36.15	29.82
1 3/4	1 1/2	3/4	1/4	2 1/4	AT49616	38.45	31.72
2	1 1/2	3/4	1/2	2 3/8	AT49618	39.65	32.71
2 1/4	1 3/4	7/8	1/2	2 3/4	AT49619	59.10	48.76
2 1/2	2	1	1/2	2 7/8	AT49620	62.85	51.85

Bullnose Radius Bits

- 2 flute

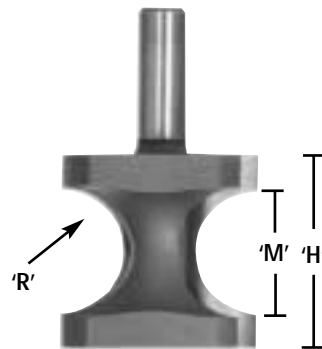
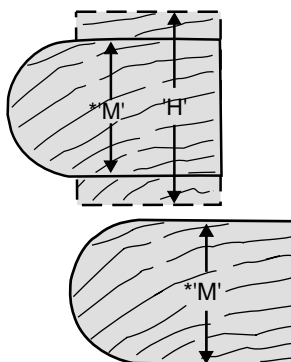

'M'	'R' Radius	'H' Cut L	Tool Dia.	Shank Dia.	OAL	Item	Price each	
							1-9	10+
1/8	5/64	1/2	17/32	1/4	1 3/4	AT51540	\$47.35	\$39.06
1/4	9/64	3/4	21/32	1/4	1 7/8	AT51544	53.30	43.97
3/8	13/64	3/4	7/8	1/4	2	AT51546	57.25	47.23
1/2	9/64	3/4	21/32	1/2	2 1/4	AT51554	53.40	44.06
3/8	13/64	3/4	25/32	1/2	2 1/4	AT51556	60.50	49.91
1/2	17/64	1	1 1/32	1/2	2 1/2	AT51558	65.45	54.00
3/4	3/8	1 5/16	1 1/4	1/2	2 3/4	AT51560	89.05	73.47
1	1/2	1 9/16	1 11/16	1/2	3 1/16	AT51562	100.85	83.20
1 1/4	5/8	2	2	1/2	3 1/2	AT51564	115.85	95.58

*'M' denotes thickness of material on which a full 180° round over can be accomplished.



* OAL-Overall Length

Cove Bits

- 2 Flute With Ball Bearing Guide

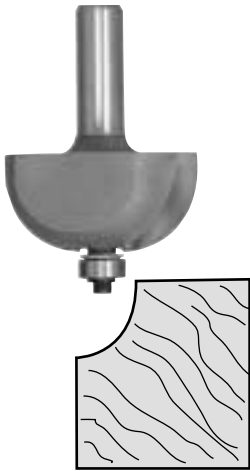

		Lg. Carbide Shank					Price each	
Radius	Dia.	Ht.	Dia.	OAL*	Item	1-9	10+	
1/16	1/2	1/2	1/4	2	AT49092	\$35.65	\$29.41	
1/8	5/8	1/2	1/4	2	AT49094	35.65	29.41	
3/16	3/4	1/16	1/4	2	AT49100	37.60	31.02	
1/4	7/8	1/16	1/4	2	AT49104	36.15	29.82	
1/4	7/8	1/16	1/2	2 3/8	AT49106	38.60	31.85	
5/16	1	1/16	1/4	2 1/8	AT49108	37.55	30.98	
5/16	1	1/16	1/2	2 3/8	AT49110	39.95	32.96	
3/8	1 1/8	1/16	1/4	2	AT49112	36.10	29.78	
3/8	1 1/8	1/16	1/2	2 3/8	AT49114	38.45	31.72	
1/2	1 3/8	3/4	1/4	2 1/4	AT49116	40.45	33.37	
1/2	1 3/8	3/4	1/2	2 1/2	AT49118	41.65	34.36	

Classical Cove Bits

- 2 Flute With Ball Bearing Guide
- Shank dia. 1/4"
- Carbide height. 5/8"

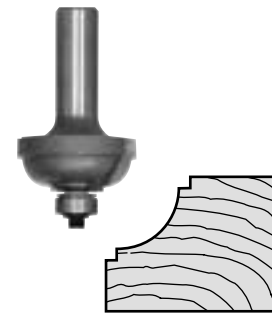

Lg. Dia.	Radius	OAL*	Item	Price each	
				1-9	10+
1 3/8	5/16	2 1/8	AT54146	\$58.45	\$48.22

Ogee Bits

- 2 Flute With Ball Bearing Guide
- Carbide height for:
AT54122 & AT54126- 11/16"
AT54124- 1/2"

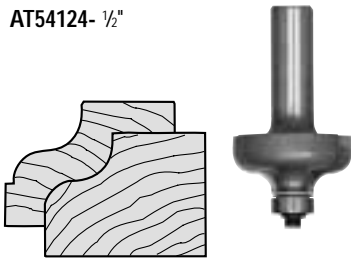

Lg. Dia.	Radius	Shank Dia.	OAL*	Item	Price each	
1	2				1-9	10+
1 3/8	1/4	3/16	2 1/4	2 3/16	AT54122	\$61.70 \$50.90
1 1/8	5/32	5/32	1/2	2 3/8	AT54124	54.85 45.25
1 3/8	1/4	3/16	1/2	2 1/16	AT54126	61.70 50.90

Roman Ogee Bits

- 2 Flute With Ball Bearing Guide
- Carbide height for:
AT49200 & AT49202- 5/8"
AT49204 & AT49206- 7/8"

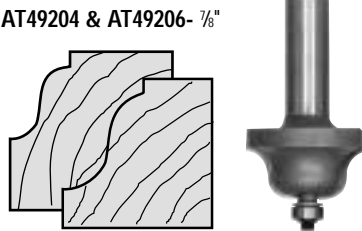

Lg. Dia.	Radius	Shank Dia.	OAL*	Item	Price each	
					1-9	10+
1	5/32	1/4	2 1/8	AT49200	\$41.15	\$33.95
1	5/32	1/2	2 1/2	AT49202	44.05	36.34
1	1/4	1/4	2 1/4	AT49204	42.85	35.35
1 3/8	1/4	1/2	2 5/8	AT49206	46.40	38.28

Double Roman Ogee Bits

- 2 Flute With Ball Bearing Guide
- Carbide height for:
AT49212 & AT49214- 7/8"
AT49208- 5/8"

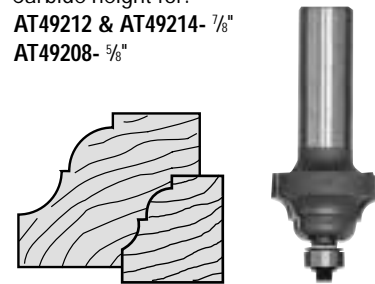

Lg. Dia.	Radius	Shank Dia.	OAL*	Item	Price each	
					1-9	10+
1	5/32	1/4	2 1/8	AT49208	\$49.90	\$41.17
1 3/8	1/4	1/4	2 1/4	AT49212	54.70	45.13
1 3/8	1/4	1/2	2 5/8	AT49214	57.20	47.19

Flat Ogee Bits

- 2 Flute With Ball Bearing Guide
- Shank dia. 1/4"
- Carbide height 5/8"

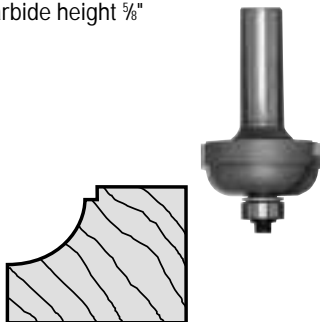

Lg. Dia.	Each Radius	OAL*	Item	Price each	
				1-9	10+
1 3/8	5/16	2 1/8	AT54154	\$55.85	\$46.08

Ogee Fillet Bits

- 2 Flute With Ball Bearing Guide
- Shank dia. 1/2"
- Carbide height. 3/4"

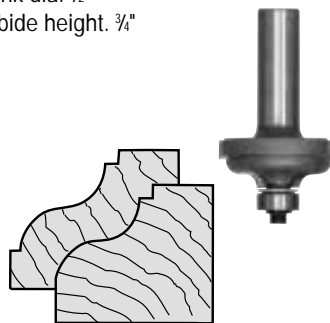

Lg. Dia.	Each Radius	OAL*	Item	Price each	
				1-9	10+
1 3/8	1/4	2 3/8	AT54114	\$58.70	\$48.43

Classical Ogee Bits

- 2 Flute With Ball Bearing Guide
- Radius 1- 1/4"
- Radius 2- 3/16"
- Large dia. 1 3/8"

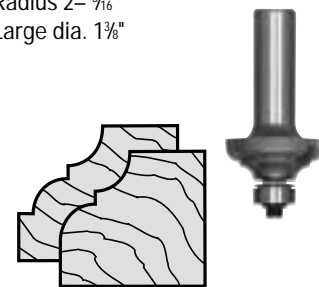

Carbide Height	Shank Dia.	OAL*	Item	Price each	
				1-9	10+
1/2	1/4	2	AT54130	\$62.25	\$51.36
1 1/16	1/2	2 1/16	AT54134	62.25	51.36

- Check out Closet & Shelving Hardware
- Check out Sliding Door Hardware

* OAL-Overall Length

Core Box Bits

- 2 Flute

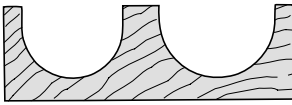

Cut Carb. Shank		Price each			
Dia.	Ht.	Dia.	OAL* Item	1-9	10+
1/8"	3/8"	1/4"	1 3/4" AT45900	\$22.10	\$18.23
3/16"	1/2"	1/4"	1 3/4" AT45902	22.10	18.23
1/4"	1/4"	1/4"	1 5/8" AT45904	23.25	19.18
3/8"	1/4"	1/4"	1 1/2" AT45906	26.40	21.78
3/8"	1/4"	1/2"	2" AT45908	31.00	25.58
1/2"	3/8"	1/4"	1 1/2" AT45910	27.00	22.28
1/2"	3/8"	1/2"	2 1/8" AT45912	32.15	26.52
5/8"	7/16"	1/4"	1 5/8" AT45914	27.20	22.44
5/8"	7/16"	1/2"	2" AT45916	36.15	29.82
3/4"	7/16"	1/4"	1 3/4" AT45918	28.70	23.68
3/4"	7/16"	1/2"	2" AT45920	38.70	31.93
1"	5/8"	1/4"	1 3/4" AT45924	44.55	36.75
1"	1 1/16"	1/2"	2 1/8" AT45926	55.95	16.16
1 1/4"	3/4"	1/2"	2 7/16" AT45928	66.00	54.45

Dovetail Bits

- 2 Flute

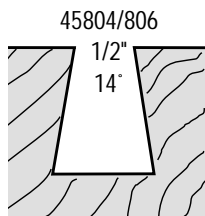

Cut Carb.		Price each		
Deg. Dia.	Ht.	OAL* Item	1-9	10+
1/4" Shank Dia.				
9°	3/8"	3/8" 1 5/8" AT45800	\$19.95	\$16.46
14°	1/2"	1/2" 1 3/4" AT45804	19.95	16.46
1/2" Shank Dia.				
9°	3/8"	3/8" 2 1/8" AT45802	21.10	17.41
14°	1/2"	1/2" 2 3/8" AT45806	22.50	18.56
7°	7/8"	7/8" 2 3/4" AT45812	38.45	31.72
14°	1"	1" 2 3/4" AT45814	37.75	31.14

Glue Joint Bit

- 2 Flute
- Shank dia. 1/2"



Second piece is cut 'upside-down' to the first for a perfect fit. There is no need to realign the router depth, provided that the wood is centered to the cutting edge of the bit. For 3/8" through 1" material.

Cut		Price each		
Dia.	L	OAL* Item	1-9	10+
1 1/8"	1 3/2"	2 3/8" AT55388	\$97.25	80.23

Special Order Only
Please allow up to 1 week for delivery.

Tongue & Groove Assembly

- 2-Wing with Ball Bearing Guide
- Shank dia. 1/2"
- Carbide height. 3/4"

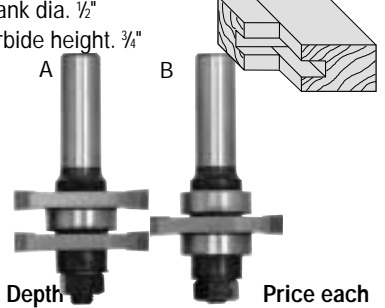

Depth		Price each	
Dia. Of Cut	OAL* Item	1-9	10+
1 1/8"	3/8" 3 AT55400	\$71.85	\$59.28

Can be used on 1/2" through 3/4" thick material. Tongue is cut as shown in assembly 'A'. For groove cut, reassemble the tool as shown in 'B'. Instructions included.

45° Lock Miter Bit & Mini Lock Miter Bits

- 2 Flute
- Shank dia. 1/2"
- Carbide height. 1 3/8"

First piece is cut flat (horizontal) and the second is cut perpendicular (vertical) to the first for a perfect fit. There is no need to re-align the router depth, provided that the wood is centered to the cutting edge of the bit. Not recommended for use in a pin router nor a router table unless the length of your material can be handled easily.

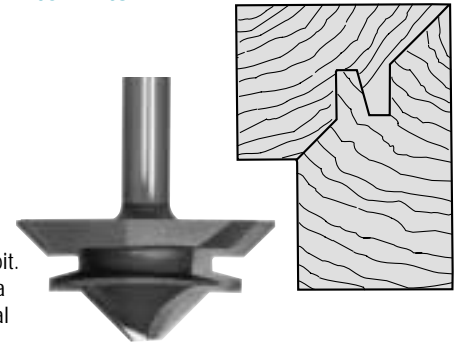

Special Order Only
Please allow up to one week for delivery.

Material		Price each	
Dia.	OAL* Size Item	1-9	10+
2 1/16"	2 3/8" 1/2-3/8" AT55390	\$147.55	\$121.73

Router Bit Replacement Parts

- Steel Ball Bearing Guides
- Fractional Listed By Size/Steel Shields & New Teflon® Shields

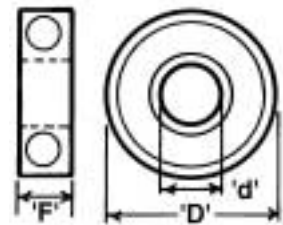

Application:
3/8" diameter flush trim, all beading bits, (49300/49302), 49340, 49350, 49540, 49542, 49550, many types of form bits.

'd'	'D'	'F'	Price each		
Inside Dia.	Outside Dia.	Width	Item	1-9	10+
3/16"	3/8"	.124 (1/8")	AT47702	\$4.60	\$3.80

Application:

Our most popular bearing. Fits 1/2" diameter flush trim, some bevel trim, all corner rounds, raised panel, rabbet, ovolo, many types of form bits and 51570, 54160, 54162, 54198, 54370 & new style 54200 & 54220.

'd'	'D'	'F'	Price each		
Inside Dia.	Outside Dia.	Width	Item	1-9	10+
3/16"	1/2"	.195 (3/16)	AT47706	\$3.75	\$3.09